



sartorius

## PR 5210

### Process Transmitter



- Full Digital Signal Processing with up to 4.8 Mio Divisions Internal Resolution
- High Performance Sense Amplifier Circuit for Maximum Accuracy
- SmartCalibration feature for fast calibration even without weights
- Direct calibration and configuration via Windows-PC
- W&M approval for 6000e, class III (EN 45501/OIML R76)
- Supply voltage 24 V<sub>DC</sub>
- Protection class IP 20, DIN-Rail mounting

#### Product profile

The PR 5210 series of Digital Process Transmitters combine reliable and accurate weight acquisition with extremely easy operation and setup.

Three versions are available:

- PR 5210/10 with a high-performance 16 bit analogue output
- PR 5210/11 with high-speed 12 Mbit Profibus-DP interface
- PR 5210/00 providing both

Users can access directly all configuration and operation levels via the front serial interface. A Windows Engineering Tool allows convenient configuration from a Windows PC or Laptop.

All instrument feature a built-in RS422/485 serial interface using the very simple and versatile SMA-Standard protocol.

#### Description

The transmitter is specifically designed for use in typical control cabinets. It combines convenient DIN rail mounting with fast setup and straight forward configuration in a very simple way.

Multiple instruments can be easily lined up in the control cabinet and the full galvanical isolation of all input and output circuits from supply makes the instrument especially easy and safe to integrate.

The direct-access Windows Engineering Tool makes the instrument ideal for all applications where ease of use and a simple but effective data acquisition of weight values is required.

A set of typical built-in weighing functions support adaptation to individual process requirements without programming. The configurable digital Inputs and Outputs and the limit/alarm function with user-configurable hysteresis can be combined to provide simple but reliable direct process control.

#### Profibus-DP, 12 Mbit (PR 5210/00 + /11)

High-speed Profibus-Interface to connect to PLCs and SCADA systems. Provides weight values at maximum accuracy and speed.

#### Smart Calibration

The easiest and fastest way to a reliable calibration even without weights due to high precision input amplifier and reference circuit.

#### Input signal filter

Powerful digital low pass filter to suppress unwanted signal variation caused by external disturbances. Variable cut-off frequency and selectable filter style.

#### Password protection

User definable pass code to prevent unauthorised access to parameters or calibration data.

### Sensor Input

Sensor input circuit and supply fully galvanically isolated from supply voltage and all in-/output circuits.

### Sensor supply

12 V<sub>DC</sub>, max. 160 mA (= 75 Ω)  
4- or 6-wire-circuit

### Input range

0... 36 mV, internal Res.: 7.5 nV  
(appr. 4.8 Mio div.)  
usable stepwidth: 200 nV  
Linearity < 0.002 % (typ.)

Dead load suppression 0... 100 %

### Sample interval

10, 20, 40, 80, 160 ms  
user selectable

### Accuracy

6000e, Class III  
0.5 μV/e @ 6 samples/sec

### Status LEDs

Status LEDs to signal operation and error conditions.

### In-/Outputs

All I/O circuits fully galvanically isolated from sensor input and supply.

### Profibus-DP (PR 5210/00 + /11)

12 Mbit, DP-V0  
IEC 61158 Type 3 and IEC 61784

### Analogue Output (PR 5210/00 + /10)

0/4... 20 mA, internal resolution 16 bit,  
usable stepwidth: 0.5 μA  
max. load 500 Ohm  
user configurable

### Digital I/Os

Function user configurable  
3 x IN, 30 V, 10 mA  
3 x OUT, 30 V, 30 mA

### Serial Interfaces

RS 232C via RJ-12 for configuration only  
RS 422/485 via screw terminals  
Protocol: Remote Display

### Environmental conditions

Operation: -10... +55° C  
Storage: -20... +70° C  
Humidity: 90 % RH, non-condensing  
Vibration acc. to DIN EN 680068-2-6 /Fc

### Supply

24 V<sub>DC</sub>, +10/-15 %, 8.2 W max.

### Conformity

EN 61000-6-2 and 61000-6-4  
NAMUR, CE

Protection: housing/terminals IP20  
Mounting: 35 mm DIN rail (DIN46277)  
All electrical connections via modular screw terminals for 2.5 mm<sub>2</sub> max.  
System Phoenix/COMBICON  
Dimensions: 99 x 116 x 45.2 mm  
Weight: 0.29 kg net

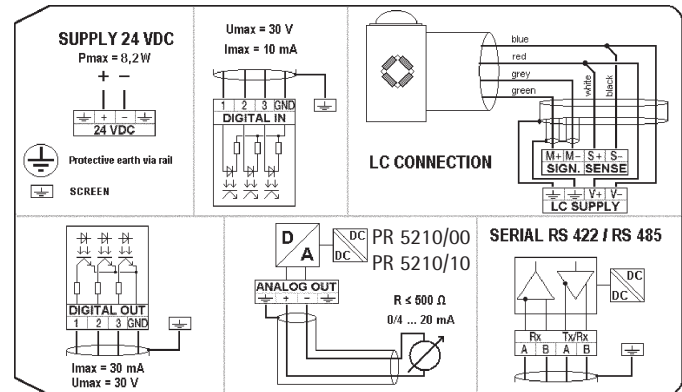
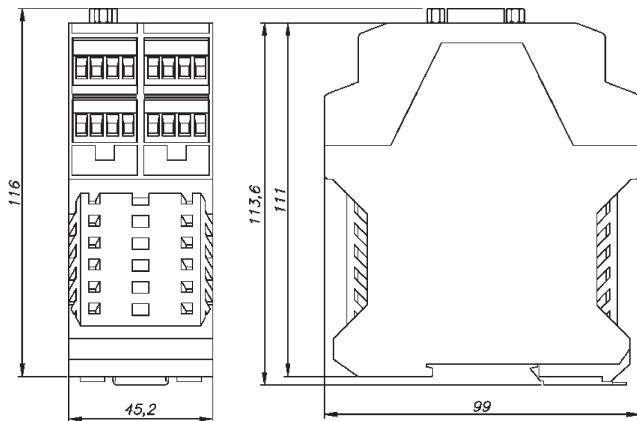

### Order information

Type	Description	Order number
PR 5210/00	Profibus-DP, Analogue Output, Digital I/O, Serial Interface	9405 152 10001
PR 5210/10	Analogue Output, Digital I/O, Serial Interface	9405 152 10101
PR 5210/11	Profibus-DP, Digital I/O, Serial Interface	9405 152 10111

Delivery: incl. CD containing Manual, Engineering Tool, GSD file, serial cable for PC connection (Sub-D to RJ-12)